

karich
industrial design studio

www.karichdesign.com

summary

- 01. tableware
- 02. accessories
- 03. wood furniture
- 04. metal furniture
- 05. lighting
- 06. experimental designs
- 07. research projects
- 08. recent press

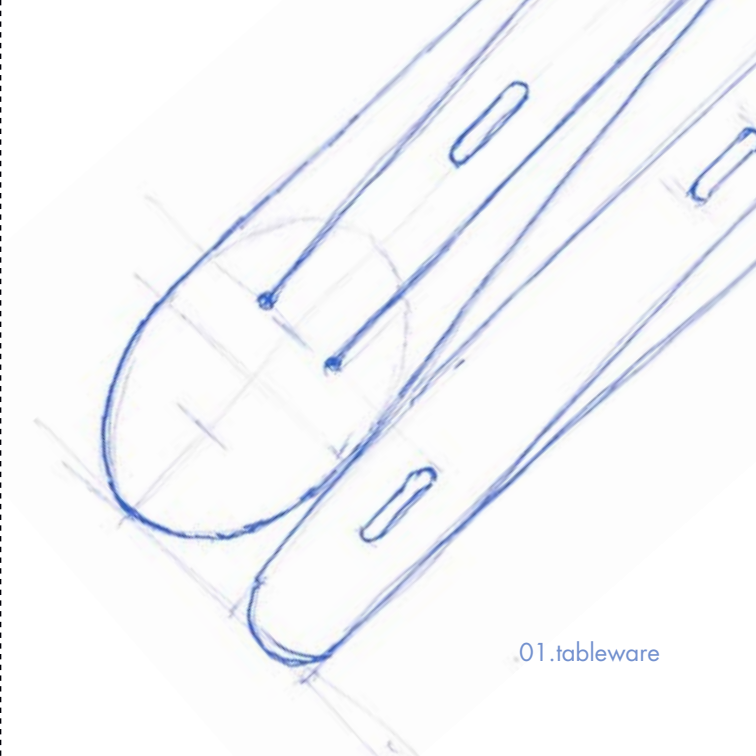
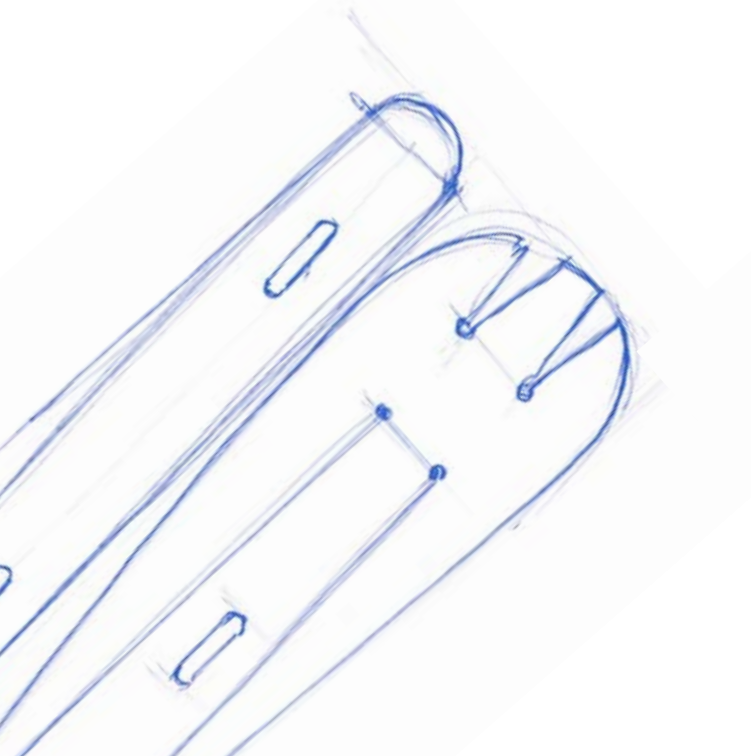

01.tableware



flat salad set

The purpose of this project was to transform plastic materials typically categorized as rubbish: water bottles, water jugs, packaging and plastic containers into real home functional objects that reveal the beauty of individual components. And being aware of the limitations and discovering new forms through the potential of craftsmanship to stand up to a world highly industrialized. Having all this in perspective I started to work with empty bottles trying to extract shapes similar to cutlery, to finally achieve a salad set that comes out from flat single surfaces and that come in shape in a simple way and becomes elegant and beautiful.



goldfinger



The "goldfinger" fork is quite simple, you just hold the fork between the index (inside) and the thumb (outside), the symmetry allow the fork to be used by right handed and lefty's as well. It's a very simple occasional cutlery, it's perfect for cocktail parties or all kind of catering events.

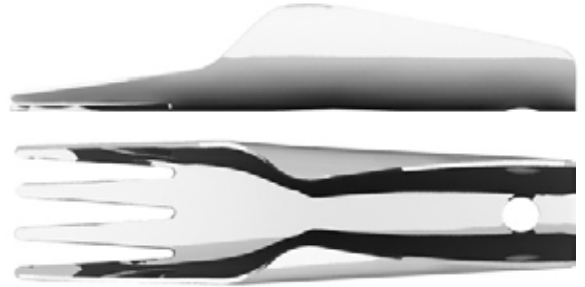

juicy hook



The juicy hook is a rubber flexible piece with a solid aluminum cast handle and squeezer. Depending on the use, the rubber part can be used to hold the juice extracted or just simply to protect your hand from getting wet with the juice. At the same time the rubber allows the squeezer to stand when you are not using it.

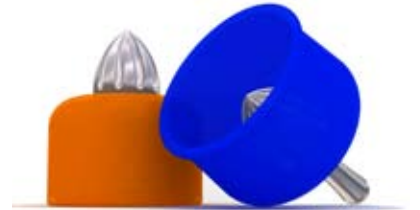



punch coffee mug

This coffee cup reminds you that getting up is hard, you need strong coffee and a good punch in the face to get going. This cup is not for mobsters, gangsters or hooligans, we advice people to use this cup for coffee drinking purposes only. White Ceramic finish for beginners, silver coated for abusive users.



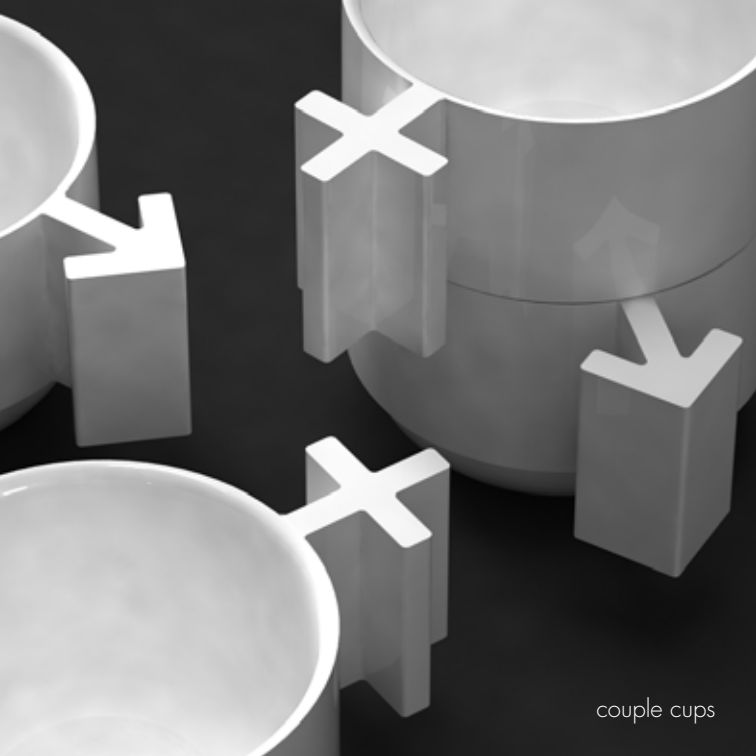

couple cups

This is a set of two cups in porcelain or melamine. I've called them "couple cups" because of the handles; the cups have two different grips representing male and female symbols. These cups are also stackable. I wanted to design a new simple cup, for serving coffee & tea trying to create a cup with a shape that can be easily recognized by its handle, the essence of the project.



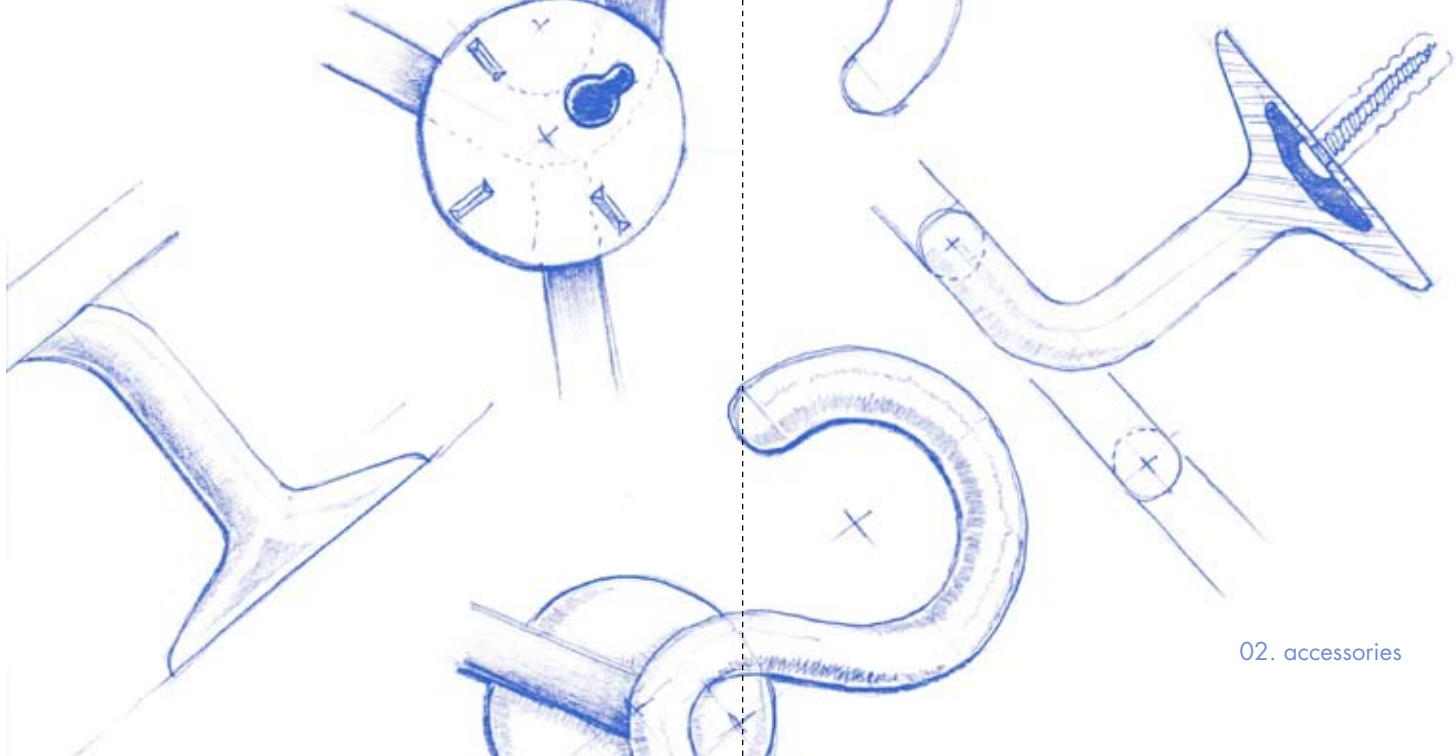

02. accessories

wall valet



The "valet de chambre", a furniture store that allows proper clothing before or after their daily use. To give this element a new life or better a new form of using it, the most important thing is to reduce the space needed for this kind of accessory. In this way the Wall Valet offers an alternative and very simple form of organizing that can satisfy the basic needs of fast storage. Wall backed by a single point it can be used to hang shirts, jackets, pants and others.

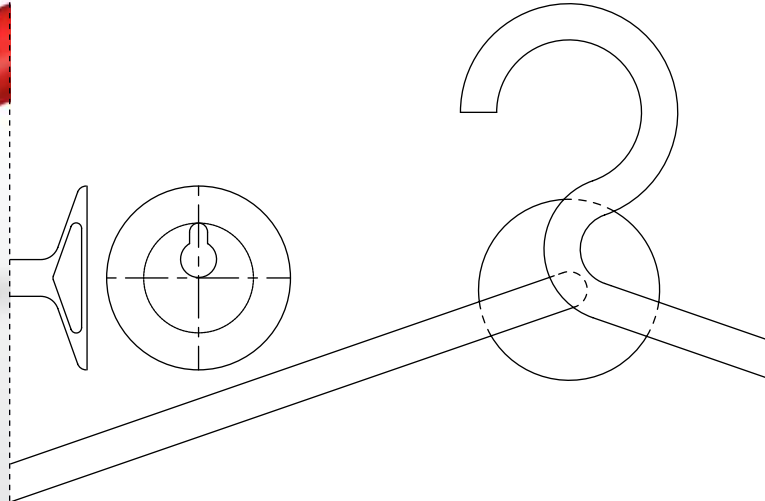

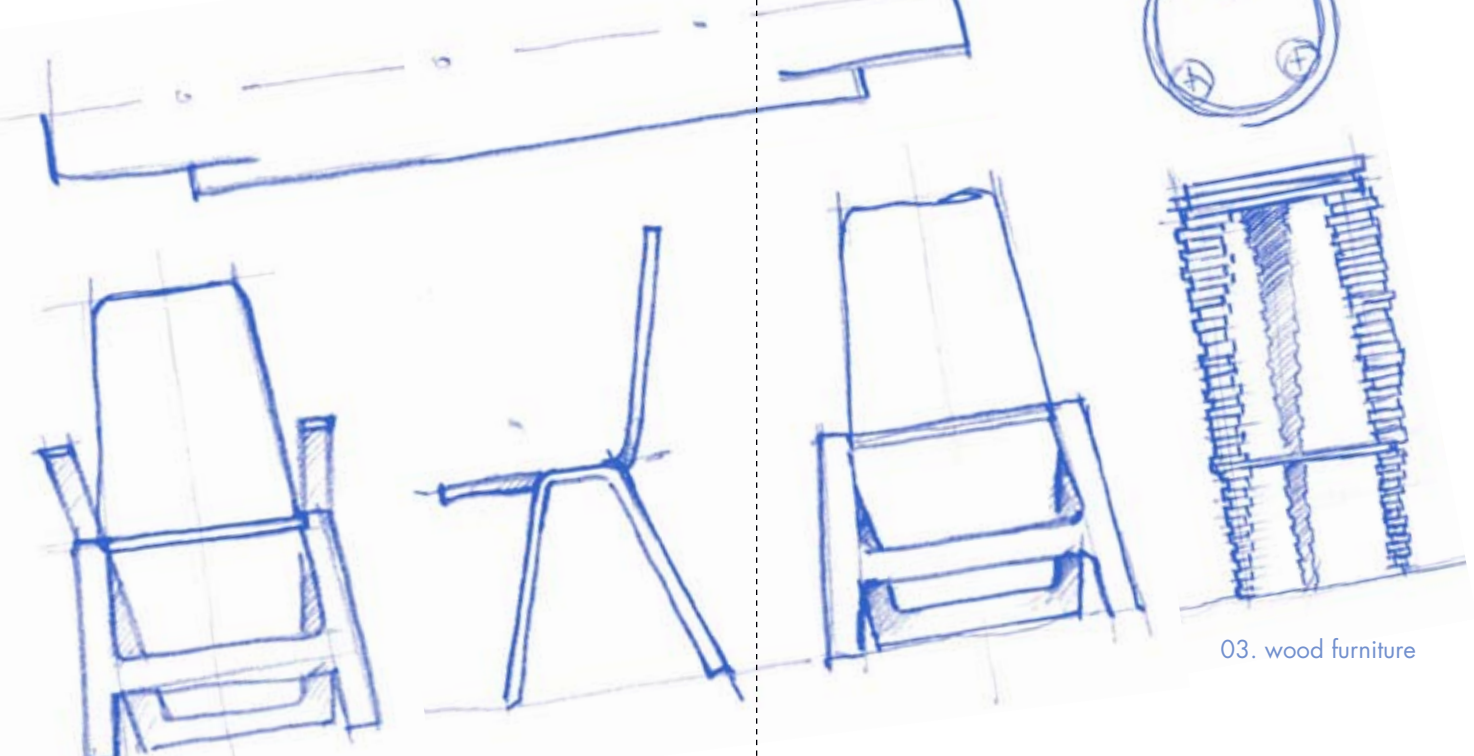

03. wood furniture

canyon stool



The "Canyon" stool, is a very simple yet sculptural piece of furniture, it made out of discs of solid wood, these discs are piled up increasing in diameter all the way up to the seat composed of 3 larger diameter discs, all the discs are mounted disaxed. This gives the stool a particular organic and sculptural shape.





network chair

Network, elegant and functional. A complete scale of executions with variety of applications. The chair consists of bend Beech wood, Oak wood or Walnut plywood cut-out and is a very versatile concept. The chair comes into shape by a bend operation with 3 parallel axes of a simple plywood board and that's all. In a grid the chairs cut-out shape fits with each other perfectly and with no space between them, constituting a network in all directions.

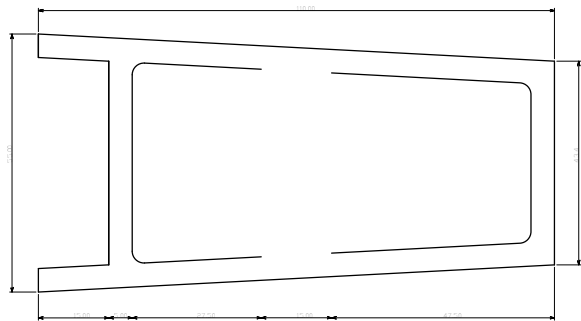

40x40 armchair



40x40 is a small armchair made only from cut sections of a 40x40mm fir or oak natural wood, this simple shape forming a more complex structure with the only particularity of having different lengths, glued and nailed together. The primal look of this chair is basically due to the simple and raw construction concept.

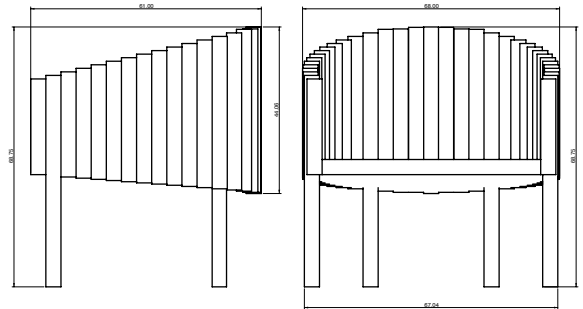

canyon stool



The "Balansoir" stool is the result of a very special concept, that can reach a great number of people, because it is a seat that adapts its function to 2 very different uses. It can be used as a bar stool (for adults) in its vertical position and as a swing seat (for children in horizontal position). The top and backside have handles to allow changing the seat's position easily. A foot bar structures the lower part.

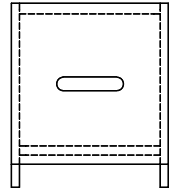
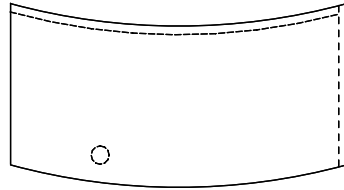

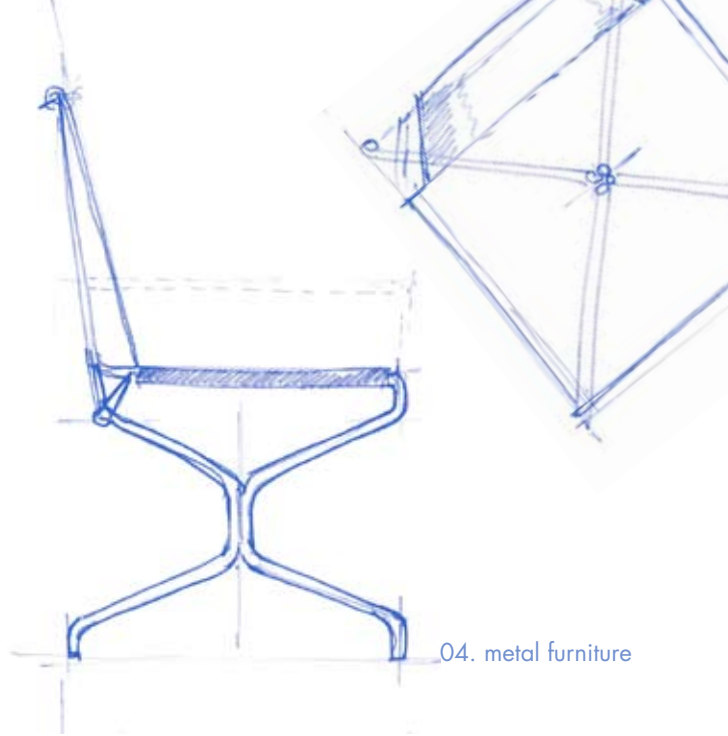

04. metal furniture

be red chair



Balance was the main concept for this chair, having a single and continuous line that creates a structure's backrest, seat and armrests. This chair is made of chromed steel tube with polypropylene back and seat pieces. The two front legs are not traditional and give the chair a very distinctive look.

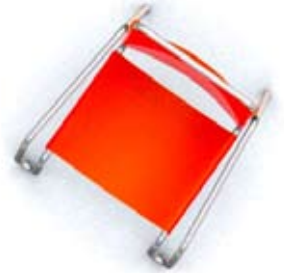



grace chairs

« Grace » is a seating system that includes a chair, a stool and an armchair, the main concept was to seek for a flexible and soft gesture, generating the maximum of sensations with the minimum resources, using strong a traditional materials that can reduce thickness and dimensions to obtain a very thin composition and a visual balance above all.

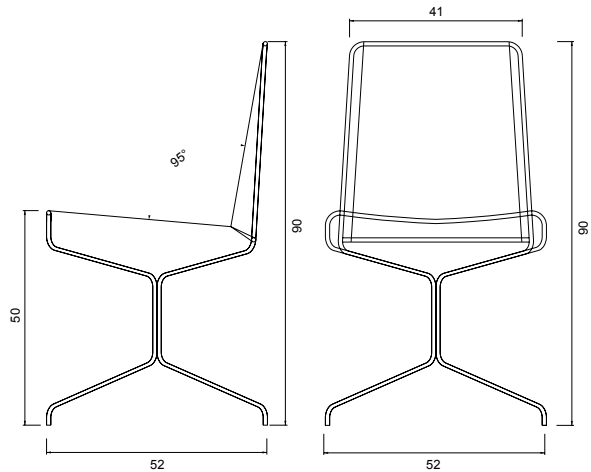



knot chair

"Knot" is a chair made of stretched canvas by 4 curved metal bars. It is a lightweight structure for a simple and elegant chair that can be used in a work environment or can have a domestic use, different choice of fabric or other materials allows for adaptability to the context.



tt desk



Office or small table supported single chrome steel trestle with a wooden tablet. With the offset of the trestle and its asymmetrical design, the tray is in balance and its stability is enhanced when it is an object. There is no mechanism or attachment complex. Its components are up and being put in place easily. The space once stored is minimal.



orbit stool



This is a light wireframe structure stool with a wooden seat. The concept for this stool was to make something out of very few parts (4) legs, rings and seat. The upper ring is very useful when it comes to pick up or move the stool, this because of the small gap between the seat and the exterior ring (O stands for orbit, the ring trace and orbit around the seat) and the lower ring is a little wider to perfectly become a nice comfortable foot rest when in use. Materials are brushed stainless steel structure and the seat is solid beech wood or oak.





gerrit study chair

This chair is a tribute to Gerrit Rietveld's work, and the approach was funny in two ways, first to include elements from the beginning of the 20th century in furniture design and also elements from De Stijl and Gerrit's work. These elements are present in the steel tube structure, the colors and the simplicity of the whole chair, I found it interesting to make a study chair with a writing tablet that remembers some of the basic principles of contemporary furniture design.



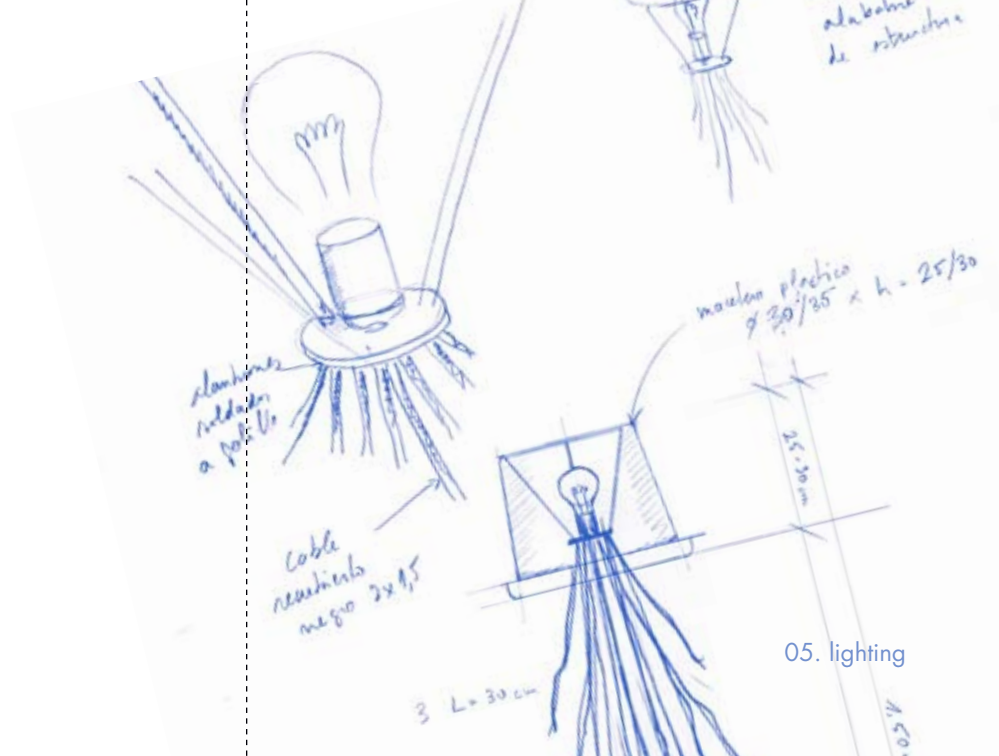



The plant lamp, is a delicate object, always in balance, supported and structured by thin wire legs, between these wires only a couple go all the way to the wall outlet. The shade is a real plant pot, upside down, clay colored but plastic made it directs light up and down while glowing with a warm red and light brown colour. The plant lamp can be scaled from a desk lamp, to a standing lamp or a pendant lamp.





The "Swan" lamp, is a very simple lamp that takes form from a single folded piece of steel or aluminium plate. After being folded it takes a shape that reminds you of a swan, elegant and light shape. The shade is in the upper part, with a small perforation that can receive the lightbulb support. It's a small and simple lamp, made of a few simple folding operations, the back side leaves place for the cord to run down easily.

steel die cut unfolded

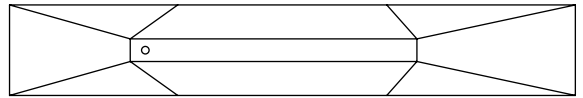

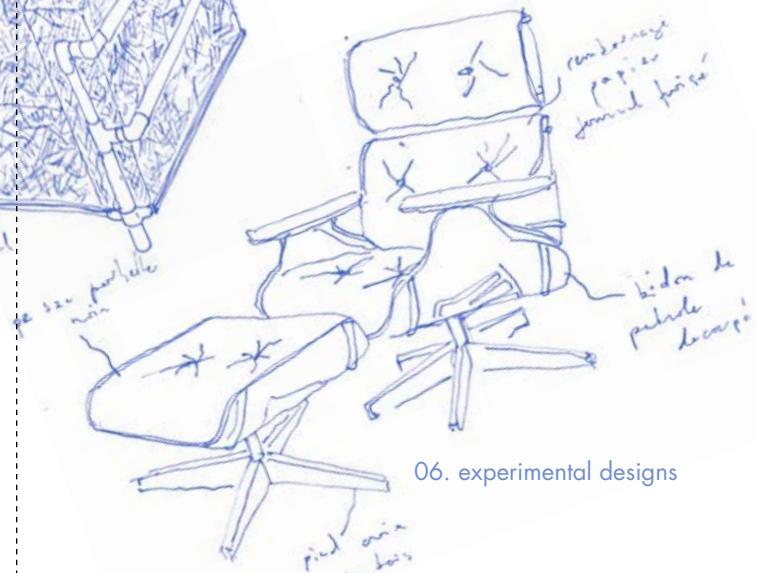
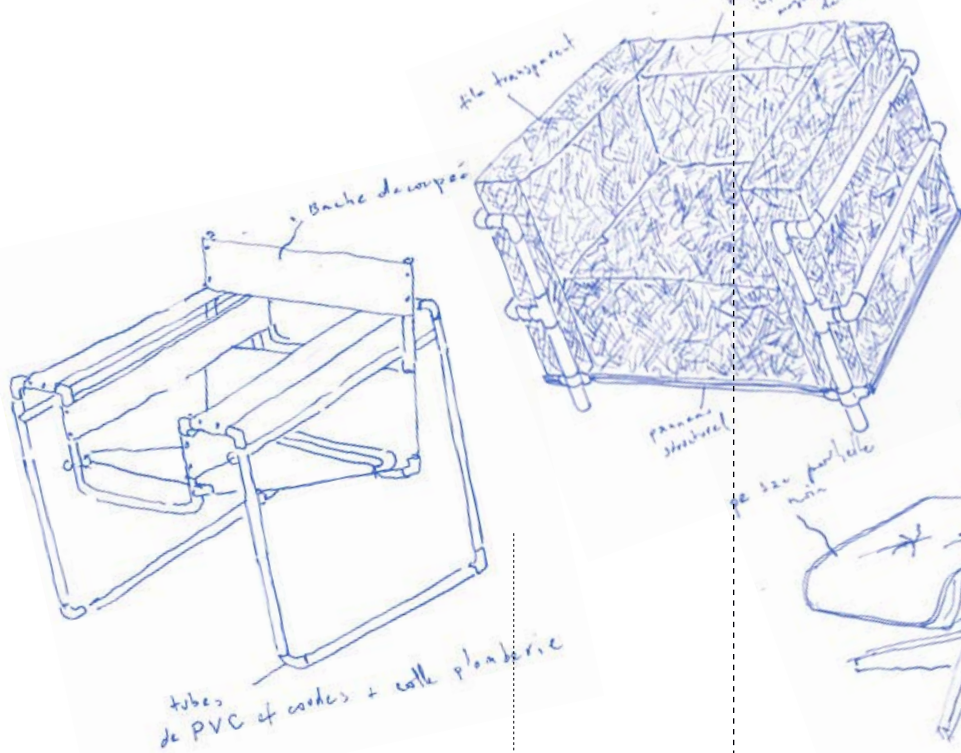

06. experimental designs

skate chair



The skate chair is an experimental design, reusing skateboard to compose a low seat, the electric board design enhance the look of his furniture piece. Five board are putted together with two shiny chromed legs. The board can be upholstered with leather to improve the comfort of this original chair.





shredded LC3

This seat particular version of the famous le corbusier armchair is made out of recycled materials, shredded magazines sealed inside transparent bags, the structure is made of bus hand railings. It belongs to a series of furnitures I've called "reconsidered masterpieces".



the artist rest

The artist rest is a sculpture furniture object, it has two black canvas frames, upholstered. The legs and armrests are made of gold picture framing.

In the same series of furnitures called "reconsidered masterpieces" I created a version of Breuer popular armchair, it's made of cheap construction materials like pvc.



easy wassily

Casino chairs are just a game, build and play using a deck of playing card, but while some people try to make castles out of them, I always think of creating furniture objects.



casino chairs

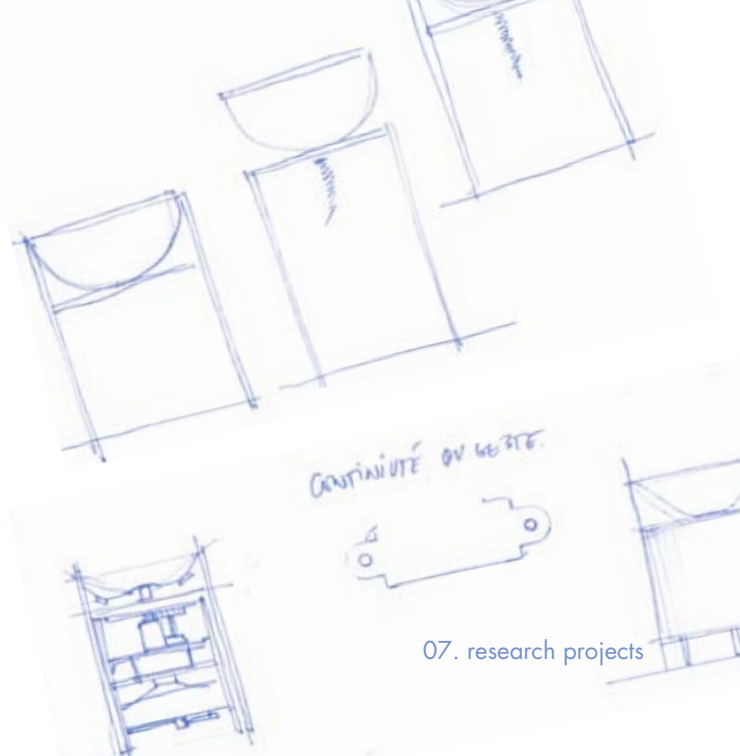
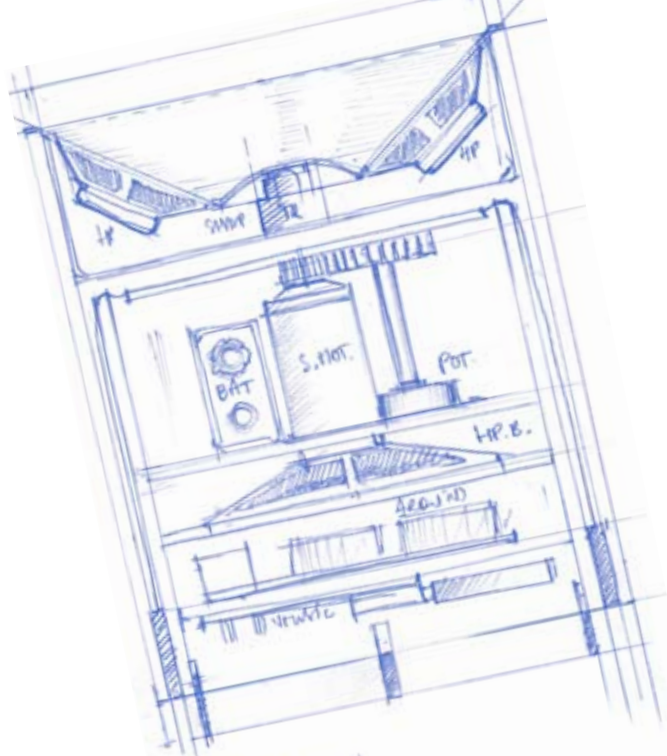

07. research projects

soundsitive
prototype



Office or small table supported single chrome steel trestle with a wooden tablet. With the offset of the trestle and its asymmetrical design, the tray is in balance and its stability is enhanced when it is an object. There is no mechanism or attachment complex. Its components are up and being put in place easily. The space once stored is minimal.



08. recent press

FLAT SALAD
pandoradeign
milano



"Flat Salad" del Karich, sono due fogli di plastica che con semplici movimenti diventano posate da servizio, perfette per essere vendute con le riviste ... di lusso!



 Flat Salad

2007 design: J. Christophe Karich

Posate da servizio
Serving cutlery

Plastica
Plastic

FISTICUP™ / This man-size coffee mug packs a serious punch!

Do you take your morning brew light and sweet, or are you a hard hitting black coffee type? Either way, you'll get a fistful of your favorite beverage with this smashing new mug. Sleek ivory high-fire ceramic contrasts dramatically with the steely metallic handle. Packaged in a full-color illustrated giftbox.

Design: Jean Christophe Karich

©2009 FRED



#FRED2009 FISTICUP_BOX CYAN YELLOW MAGENTA BLACK PMS677C (GOLD NOT PRINT)



wallpaper
dec 06



Learning an excellent lesson from a visit to the workshop of Thommay and Thibaut de Campana, the brothers designed the 2001 master plan. People's idea of how a neighborhood looks - but things are a little different here in Bordeaux. They recently the study of the estate in the south-west of France (they live in a white of each being design model) which have become the staff of inspired. Each course is led by a different designer, and this time was the Campana brothers - who have been in their like studio respectively - developing programs to give residential objects some and architectural ones. The architect's work is a free and

circled text: "The workshop at Bordeaux..."

...the workshop at Bordeaux... the idea of a neighborhood with the Urban Design Museum and the Campana Centre in Paris. They draw in people from all around the world, most of whom have found by word of mouth and have felt delighting to see a place from a novel way to the Bordeaux visitor (and) their works are. Among the 200 in projects on the landscape system are Bordeaux, Orleans, Paris, Toronto, Montevideo and Palermo, all of which have made their way to the various parts of the Campana system but focusing what is unique.

The master of Bordeaux is tomorrow's...
Hugoberto, the director of the Urban Design M...

Camp Campana

We didn't know we liked summer camp until we dropped in at the idyllic, Boisbuchet estate in south-west France, where residential workshops are led by those at the forefront of contemporary design. Luckily for us, it was the Campana brothers' week in charge.



(u.k.)

interni
nov 08



Специальный репортаж 1

3



Contex
Лампа, Чили, 2004
Специальное построение - строительная компания, которая переобладала офисное пространство, места для отдыха и обучения сотрудников и т.д. Функционально разные части здания получили и разную форму конфигурации, и окраску.



4



5

Montes House
Козлему, Чили, 2006
Участок, окруженный виноградниками и сосновыми лесами, нагорной ландшафт с суровыми климатическими условиями, когда строить на этом же участке церкви. El Roble Chapel.



PlantLamp
Ницца, Франция, 2007
Студия по форме архитектуры занимается и мебельными дизайнами: лампы-растения (Plant) из пластика и в стиле скандинавского Эрнесто Барелли Караччи (Christoph Kowitz).



Фотография предоставлена ST Studio

(russia)



El diseñador Juan Cristóbal Kariche con su silla de oficina diseñada en el estudio de diseño de su firma, Kariche Design, en Nueva York. Foto: F&F. El color rojo es un detalle de su diseño.

DISEÑADORES DE EXPORTACIÓN

Desde Nueva York, Londres, Nueva York y México, estos diseñadores chilenos están conquistando el mundo. Buscando aprender experimental y por sobre todo, escapan de una rutina que incluye el día a día, y que ahora les hace demasiado con ellos los años de exportación de diseño industrial, gráfico, webdesign y arquitectura.

Por: Alejandro Soto



La silla diseñada por Juan Cristóbal Kariche para su estudio de diseño, Kariche Design, en Nueva York. Foto: F&F. El color rojo es un detalle de su diseño.



El taburete diseñado por Juan Cristóbal Kariche para su estudio de diseño, Kariche Design, en Nueva York. Foto: F&F. El color rojo es un detalle de su diseño.



Diseño de la taza diseñada por Juan Cristóbal Kariche para su estudio de diseño, Kariche Design, en Nueva York. Foto: F&F. El color rojo es un detalle de su diseño.

JUAN CRISTÓBAL KARICHE UNIVERSAL, PERO CON IDENTIDAD

Desde, al sur de Francia, en una ciudad pequeña con un clima cálido de sol, mucha brisa y poca lluvia, algo que siempre acompañará en el momento de estar en el estudio de Juan Cristóbal Kariche. Él vive en la zona de la Costa Brava, y para él, el momento de estar en la playa es el que más le gusta. Él es un diseñador que vive en un mundo que cambia constantemente, pero siempre con un hilo rojo que lo conecta con su identidad. Él es un diseñador que vive en un mundo que cambia constantemente, pero siempre con un hilo rojo que lo conecta con su identidad.

—La idea de él es que siempre sea un diseñador que vive en un mundo que cambia constantemente, pero siempre con un hilo rojo que lo conecta con su identidad. Él es un diseñador que vive en un mundo que cambia constantemente, pero siempre con un hilo rojo que lo conecta con su identidad.

El mundo de él es un mundo que cambia constantemente, pero siempre con un hilo rojo que lo conecta con su identidad. Él es un diseñador que vive en un mundo que cambia constantemente, pero siempre con un hilo rojo que lo conecta con su identidad.



El set de cubiertos para el estudio de Juan Cristóbal Kariche para su estudio de diseño, Kariche Design, en Nueva York. Foto: F&F. El color rojo es un detalle de su diseño.

the eco-travel
handbook
sept 08
Thames &
Hudson

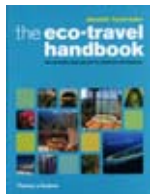

Flat Salad
Whether you are a Sunday afternoon
leash-tugger or a serious fitness
puffer, your flat demands attention to
weight and "backbite". Designer J. C.
Karah thought about both these issues
as he developed prototypes for his
flat-pack cutlery. With his salad servers
desert spoons and other tableware,
Karah reminds us of the innate beauty
of plastic, and creates a design that we
simply can't throw away, but bring
back for another day.

- Pandora Paderborn, Italy and
J. C. Karah Industrial Design
Turin, France
- plastic or wood
- lightweight, flat pack

102

(u.k.)

Salon
Magazine
Oct. 09



Полезное
искусство

Подарочные вещи, полезные вещи и вещи для подарков: почему в этом разделе мы предлагаем только полезные вещи? Потому что именно они помогут вам сэкономить деньги и время, а также подарить друзьям и коллегам нечто полезное. www.salonmagazine.com



(ukraine)

A stylized, handwritten signature in black ink that reads "j.c. karich". The signature is written in a cursive, lowercase font and is underlined with a long, horizontal stroke.

j.c.karich - industrial design studio
47 av général leclerc - 75014 paris - france
tel: 0033 6 99643656 - e-mail: info@karichdesign.com